

SUNGKWANG BEND CO., LTD.  
26 NOKSANSANDAN 262-RO  
BUSAN 46757  
SOUTH KOREA

**Date:** June 12, 2019  
**Account #:** 59867  
**Journal #:** 73160

**Attn:** SU-KEUN, LEE

**Re:** Application for Design Registration

The design, as detailed in your, DWG: SKB-DWG-LIST-2019, for a Fitting is accepted for registration as follows:

**Registered To:** SUNGKWANG BEND CO., LTD. **CRN:** 0A6900.1

**Drawing #:** SKB-DWG-LIST-2019

**Drawing Revision:** 0

**Reviewer's Notes:**

1. The registration is valid until June 12/2029 only if the Manufacturer maintains a valid quality management system approved by an acceptable third-party agency until that date. Should the approval of quality management system lapse before the expiry date indicated above, this registration shall become void.
2. Scope of Product Registration: Doc. No. SKB-CRN-BC-2019 Rev 0

Contact me if you have any questions. The invoice for registration will be forwarded under separate cover.

PAUL GILL, P.ENG.  
(778) 396-2031  
Paul.Gill@technicalsaftybc.ca  
Design Administration

**cc:**

# Scope of Product Registration

Company Name : Sungkwang Bend Co., Ltd.

Doc.No.: SKB-CRN-BC-2019 Rev.0

Category of Fitting	Name of Fittings	Designation of Applicable Codes and Standards	Material Specification	Identification Marking	Maximum Allowable Working Pressure	Maximum Working Temperature	Dimensions	Remarks
A: Pipe Fittings	Elbows	ASME B16.9 / Drawing No. : SKB-R19022301 Rev.0	ASTM/ASME A/SA 234, A/SA 420, A/SA 403	According to MSS SP-25	N/A	N/A	62" to 96"	Report of Design Proof Test : - SKDPT-20141023-01
		ASME B31.3 / Drawing No. : SKB-S19022501 Rev.0	ASTM/ASME A/SA 403	According to MSS SP-25	N/A	N/A	96", 102", 110"	Calculation : - SKB-C190220-05 Rev.0
		ASME B31.3 / Drawing No. : SKB-S19022502 Rev.0	ASTM/ASME A/SA 403	According to MSS SP-25	N/A	N/A	96", 102", 110"	Calculation : - SKB-C190220-06 Rev.0
	Tees	ASME B16.9 / Drawing No. : SKB-R19022302 Rev.0 SKB-R19022303 Rev.0 SKB-R19022304 Rev.0 SKB-R19022305 Rev.0 SKB-R19022306 Rev.0 SKB-R19022307 Rev.0	ASTM/ASME A/SA 234, A/SA 420, A/SA 403	According to MSS SP-25	N/A	N/A	62" to 84"	Report of Design Proof Test : - SKDPT-20141031-02
		ASME B31.3 / Drawing No. : SKB-S19022503 Rev.0 SKB-S19022504 Rev.0	ASTM/ASME A/SA 403	According to MSS SP-25	N/A	N/A	88", 88"x72", 96", 102", 110"	Calculation : - SKB-C190220-07 Rev.0

# Scope of Product Registration

Company Name : Sungkwang Bend Co., Ltd.

Doc.No.: SKB-CRN-BC-2019 Rev.0

Category of Fitting	Name of Fittings	Designation of Applicable Codes and Standards	Material Specification	Identification Marking	Maximum Allowable Working Pressure	Maximum Working Temperature	Dimensions	Remarks
A: Pipe Fittings	Reducers	ASME B16.9 / Drawing No. : SKB-R19022308 Rev.0 SKB-R19022309 Rev.0 SKB-R19022310 Rev.0 SKB-R19022311 Rev.0 SKB-R19022312 Rev.0	ASTM/ASME A/SA 234, A/SA 420, A/SA 403	According to MSS SP-25	N/A	N/A	62" to 96"	Report of Design Proof Test : - SKDPT-20141107-03 - SKDPT-20141110-03
		ASME B31.3 / Drawing No. : SKB-S19022505 Rev.0	ASTM/ASME A/SA 403	According to MSS SP-25	N/A	N/A	102"x80", 102"x88", 102"x96", 110"x88", 110"x96", 110"x102"	Calculation : - SKB-C190220-03 Rev.0
	Caps	ASME B16.9 / Drawing No. : SKB-R19022313 Rev.0	ASTM/ASME A/SA 234, A/SA 420, A/SA 403	According to MSS SP-25	N/A	N/A	62" to 96"	Report of Design Proof Test : - SKDPT-20141107-06
		ASME B31.3 / Drawing No. : SKB-S19022506 Rev.0	ASTM/ASME A/SA 403	According to MSS SP-25	N/A	N/A	102", 110"	Calculation : - SKB-C190220-04 Rev.0

# List of Drawing

Company Name : Sungkwang Bend Co., Ltd.

Doc. No. : SKB-DWG-LIST-2019 Rev.0

Date : Mar. 06, 2019

No.	Item	Size	Drawing No.	Remark
1	45D LONG ELBOW 90D LONG ELBOW	62" ~ 96"	SKB-R19022301 Rev.0	
2	STRAIGHT TEE	62" ~ 84"	SKB-R19022302 Rev.0	
3	REDUCING TEE	62" x 54" ~ 84" x 82"	SKB-R19022303 Rev.0 SKB-R19022304 Rev.0 SKB-R19022305 Rev.0 SKB-R19022306 Rev.0 SKB-R19022307 Rev.0	
4	CONCENTRIC REDUCER ECCENTRIC REDUCER	62" x 42" ~ 96" x 94"	SKB-R19022308 Rev.0 SKB-R19022309 Rev.0 SKB-R19022310 Rev.0 SKB-R19022311 Rev.0 SKB-R19022312 Rev.0	
5	CAP	62" ~ 96"	SKB-R19022313 Rev.0	
8	45D LONG ELBOW	96", 102", 110"	SKB-S19022501 Rev.0	
9	90D LONG ELBOW	96", 102", 110"	SKB-S19022502 Rev.0	
10	STRAIGHT TEE	88", 96", 102", 110"	SKB-S19022503 Rev.0	
11	REDUCING TEE	88" x 72"	SKB-S19022504 Rev.0	
12	ECCENTRIC REDUCER	102" x 80" ~ 102" x 96", 110" x 88" ~ 110" x 102"	SKB-S19022505 Rev.0	
13	CAP	102", 110"	SKB-S19022506 Rev.0	

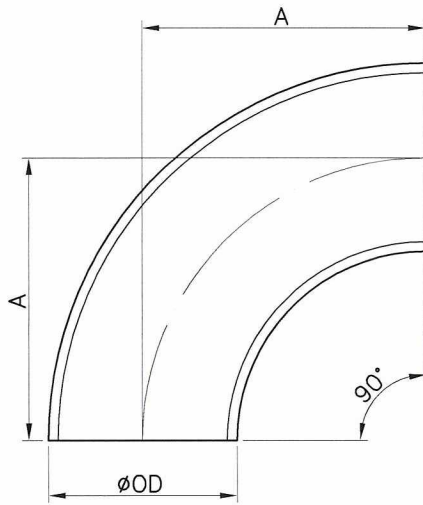

90° L-R ELBOW

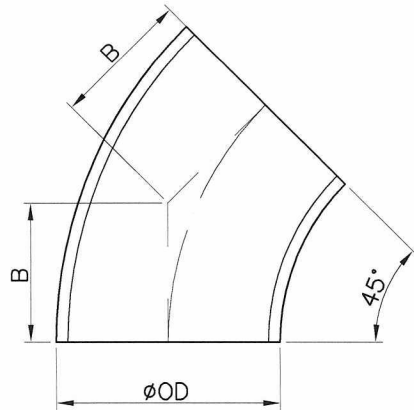



45° L-R ELBOW

SIZE(inch)	OD(mm)	A(mm)	B(mm)
62	1574.8	2362.2	978.5
64	1625.6	2438.4	1010.0
66	1676.4	2514.6	1041.6
68	1727.2	2590.8	1073.1
70	1778.0	2667.0	1104.7
72	1828.8	2743.2	1136.3
74	1879.6	2819.4	1167.8
76	1930.4	2895.6	1199.4
78	1981.2	2971.8	1231.0
80	2032.0	3048.0	1262.5
82	2082.8	3124.2	1294.1
84	2133.6	3200.4	1325.6
86	2184.4	3276.6	1357.2
88	2235.2	3352.8	1388.8
90	2286.0	3429.0	1420.3
92	2336.8	3505.2	1451.9
94	2387.6	3581.4	1483.5
96	2438.4	3657.6	1515.0

Note.

1. reference DPT Report No. : SKDPT-20141023-01.

1						TITLE	B.W L-R ELBOW			
0	FEB.23. 2019	FOR REFERENCE	K.R PARK	J.H PARK	J.H YOON	 <b>SUNGKWANG BEND CO., LTD.</b>				
REV. No.	DATE	DESCRIPTION	DRAWN	REVIEWED	APPROVED	SKB DWG No. SKB-R19022301 REV.0		SKB JOB No. N/A		
" THIS DRAWING IS THE PROPERTY OF <b>SUNGKWANG BEND CO., LTD.</b> AND MUST NOT BE COPIED OR USED FOR MANUFACTURE WITHOUT PERMISSION."						 	SCALE NONE	UNIT mm	PAPER SIZE A4	SHEET No. 1 OF 13

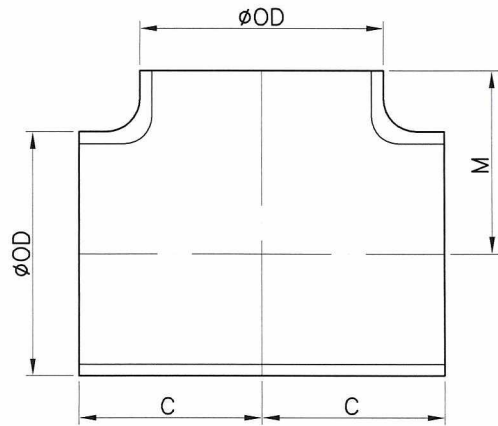

STRAIGHT TEE

SIZE(inch)	OD(mm)	C(mm)	M(mm)
62	1574.8	1210.0	1050.0
64	1625.6	1200.0	1115.0
66	1676.4	1250.0	1140.0
68	1727.2	1250.0	1150.0
70	1778.0	1360.0	1175.0
72	1828.8	1270.0	1215.0
74	1879.6	1440.0	1240.0
76	1930.4	1475.0	1270.0
78	1981.2	1510.0	1300.0
80	2032.0	1555.0	1335.0
82	2082.8	1590.0	1365.0
84	2133.6	1626.0	1396.0

Note.

1. reference DPT Report No. : SKDPT-20141031-02.

REV. No.	DATE	DESCRIPTION	DRAWN	REVIEWED	APPROVED	TITLE	SKB DWG No.	SKB JOB No.		
1						B.W STRAIGHT TEE				
0	FEB.23. 2019	FOR REFERENCE	K.R PARK	J.H PARK	J.H YOON	<b>SUNGKWANG BEND CO., LTD.</b>				
							SKB-R19022302 REV.0	N/A		
" THIS DRAWING IS THE PROPERTY OF <b>SUNGKWANG BEND CO., LTD.</b> AND MUST NOT BE COPIED OR USED FOR MANUFACTURE WITHOUT PERMISSION."							SCALE NONE	UNIT mm	PAPER SIZE A4	SHEET No. 2 OF 13

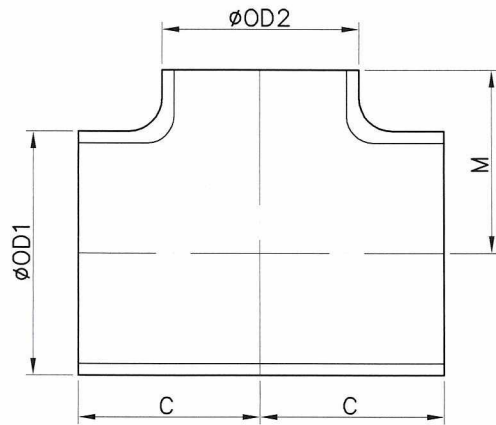

REDUCING TEE

SIZE(inch)	OD1(mm)	OD2(mm)	C(mm)	M(mm)
62 X 60	1574.8	1524.0	1210.0	1040.0
62 X 58	1574.8	1473.2	1210.0	1035.0
62 X 56	1574.8	1422.4	1210.0	1030.0
62 X 54	1574.8	1371.6	1210.0	1020.0
64 X 62	1625.6	1574.8	1200.0	1075.0
64 X 60	1625.6	1524.0	1200.0	1065.0
64 X 58	1625.6	1473.2	1200.0	1060.0
64 X 56	1625.6	1422.4	1200.0	1055.0
64 X 54	1625.6	1371.6	1200.0	1045.0
64 X 48	1625.6	1219.2	1200.0	1025.0
64 X 42	1625.6	1066.8	1200.0	1005.0
64 X 36	1625.6	914.4	1200.0	985.0
64 X 30	1625.6	762.0	1200.0	965.0

Note.

1. reference DPT Report No. : SKDPT-20141031-02.

REV. No.	DATE	DESCRIPTION	DRAWN	REVIEWED	APPROVED	TITLE	SKB DWG No.	SKB JOB No.					
1						B.W REDUCING TEE							
0	FEB.23. 2019	FOR REFERENCE	K.R PARK	J.H PARK	J.H YOON	SUNGKWANG BEND CO., LTD.	SKB-R19022303 REV.0	N/A					
" THIS DRAWING IS THE PROPERTY OF <b>SUNGKWANG BEND CO., LTD.</b> AND MUST NOT BE COPIED OR USED FOR MANUFACTURE WITHOUT PERMISSION."						SCALE	NONE	UNIT	mm	PAPER SIZE	A4	SHEET No.	3 OF 13

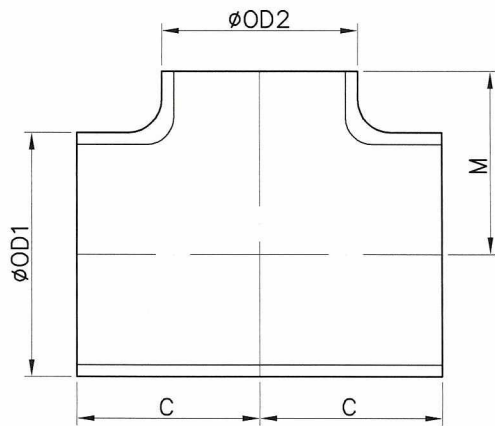

REDUCING TEE

SIZE(inch)	OD1(mm)	OD2(mm)	C(mm)	M(mm)
66 X 64	1676.4	1625.6	1250.0	1105.0
66 X 62	1676.4	1574.8	1250.0	1100.0
66 X 60	1676.4	1524.0	1250.0	1090.0
66 X 58	1676.4	1473.2	1250.0	1085.0
66 X 54	1676.4	1371.6	1250.0	1070.0
66 X 48	1676.4	1219.2	1250.0	1050.0
66 X 42	1676.4	1066.8	1250.0	1030.0
66 X 36	1676.4	914.4	1250.0	1010.0
68 X 66	1727.2	1676.4	1250.0	1135.0
68 X 64	1727.2	1625.6	1250.0	1130.0
68 X 62	1727.2	1574.8	1250.0	1125.0
68 X 60	1727.2	1524.0	1250.0	1115.0

Note.

1. reference DPT Report No. : SKDPT-20141031-02.

REV. No.	DATE	DESCRIPTION	DRAWN	REVIEWED	APPROVED	TITLE	SKB DWG No.	SKB JOB No.		
1						B.W REDUCING TEE				
0	FEB.23. 2019	FOR REFERENCE	K.R PARK	J.H PARK	J.H YOON	SUNGKWANG BEND CO., LTD.				
						SKB-R19022304 REV.0	N/A			
" THIS DRAWING IS THE PROPERTY OF <b>SUNGKWANG BEND CO., LTD.</b> AND MUST NOT BE COPIED OR USED FOR MANUFACTURE WITHOUT PERMISSION."							SCALE NONE	UNIT mm	PAPER SIZE A4	SHEET No. 4 OF 13



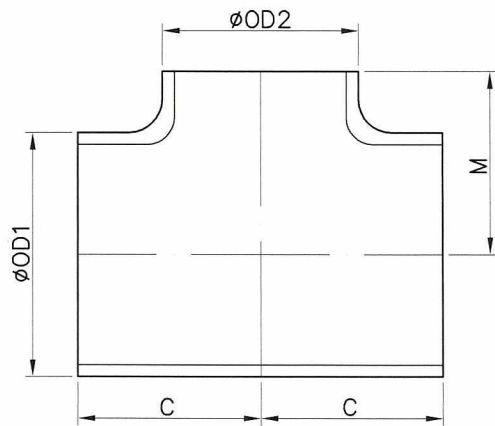

REDUCING TEE

SIZE(inch)	OD1(mm)	OD2(mm)	C(mm)	M(mm)
70 X 68	1778.0	1727.2	1360.0	1170.0
70 X 66	1778.0	1676.4	1360.0	1160.0
70 X 64	1778.0	1625.6	1360.0	1155.0
70 X 62	1778.0	1574.8	1360.0	1150.0
72 X 70	1828.8	1778.0	1270.0	1200.0
72 X 68	1828.8	1727.2	1270.0	1195.0
72 X 66	1828.8	1676.4	1270.0	1185.0
72 X 64	1828.8	1625.6	1270.0	1180.0
72 X 60	1828.8	1524.0	1270.0	1165.0
72 X 54	1828.8	1371.6	1270.0	1145.0
72 X 48	1828.8	1219.2	1270.0	1125.0
72 X 42	1828.8	1066.8	1270.0	1105.0
72 X 36	1828.8	914.4	1270.0	1085.0

Note.

1. reference DPT Report No. : SKDPT-20141031-02.

REV. No.	DATE	DESCRIPTION	DRAWN	REVIEWED	APPROVED	TITLE	SKB DWG No.	SKB JOB No.	
1						B.W REDUCING TEE			
0	FEB.23. 2019	FOR REFERENCE	K.R PARK	J.H PARK	J.H YOON	<b>SUNGKWANG BEND CO., LTD.</b>			
						SKB-R19022305 REV.0	N/A		
" THIS DRAWING IS THE PROPERTY OF <b>SUNGKWANG BEND CO., LTD.</b> AND MUST NOT BE COPIED OR USED FOR MANUFACTURE WITHOUT PERMISSION."						SCALE	UNIT	PAPER SIZE	SHEET No.
						NONE	mm	A4	5 OF 13

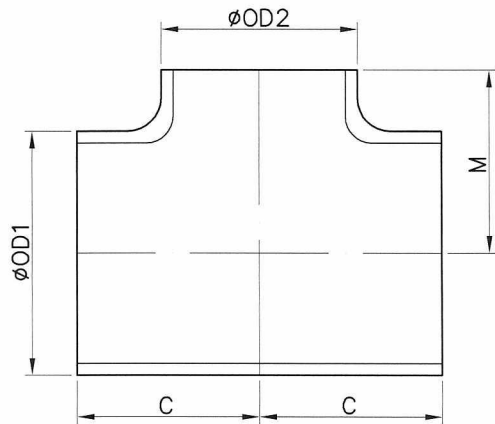

REDUCING TEE

SIZE(inch)	OD1(mm)	OD2(mm)	C(mm)	M(mm)
74 X 72	1879.6	1828.8	1440.0	1230.0
74 X 70	1879.6	1778.0	1440.0	1225.0
74 X 68	1879.6	1727.2	1440.0	1220.0
74 X 66	1879.6	1676.4	1440.0	1210.0
76 X 74	1930.4	1930.4	1475.0	1265.0
76 X 72	1930.4	1828.8	1475.0	1255.0
76 X 70	1930.4	1778.0	1475.0	1250.0
76 X 68	1930.4	1727.2	1475.0	1245.0
78 X 76	1981.2	1930.4	1510.0	1295.0
78 X 74	1981.2	1879.6	1510.0	1290.0
78 X 72	1981.2	1828.8	1510.0	1280.0
78 X 70	1981.2	1778.0	1510.0	1275.0
78 X 66	1981.2	1676.4	1510.0	1260.0
78 X 60	1981.2	1524.0	1510.0	1240.0
78 X 54	1981.2	1371.6	1510.0	1220.0
78 X 48	1981.2	1219.2	1510.0	1200.0
78 X 42	1981.2	1066.8	1510.0	1180.0

Note.

1. reference DPT Report No. : SKDPT-20141031-02.

REV. No.	DATE	DESCRIPTION	DRAWN	REVIEWED	APPROVED	TITLE	SKB DWG No.	SKB JOB No.		
1						B.W REDUCING TEE				
0	FEB.23. 2019	FOR REFERENCE	K.R PARK	J.H PARK	J.H YOON	<b>SUNGKWANG BEND CO., LTD.</b>				
						SKB-R19022306 REV.0	N/A			
" THIS DRAWING IS THE PROPERTY OF <b>SUNGKWANG BEND CO., LTD.</b> AND MUST NOT BE COPIED OR USED FOR MANUFACTURE WITHOUT PERMISSION."							SCALE NONE	UNIT mm	PAPER SIZE A4	SHEET No. 6 OF 13

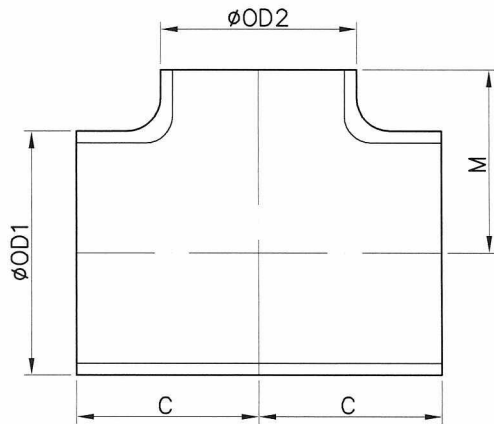

REDUCING TEE

SIZE(inch)	OD1(mm)	OD2(mm)	C(mm)	M(mm)
80 X 78	2032.0	1981.2	1555.0	1325.0
80 X 76	2032.0	1930.4	1555.0	1320.0
80 X 74	2032.0	1879.6	1555.0	1315.0
80 X 72	2032.0	1828.8	1555.0	1305.0
80 X 70	2032.0	1778.0	1555.0	1300.0
82 X 80	2082.8	2032.0	1590.0	1360.0
82 X 78	2082.8	1981.2	1590.0	1350.0
82 X 76	2082.8	1930.4	1590.0	1345.0
82 X 74	2082.8	1879.6	1590.0	1340.0
82 X 72	2082.8	1828.8	1590.0	1330.0
84 X 82	2133.6	2082.8	1626.0	1390.0
84 X 80	2133.6	2032.0	1626.0	1385.0
84 X 78	2133.6	1981.2	1626.0	1375.0
84 X 76	2133.6	1930.4	1626.0	1370.0
84 X 74	2133.6	1879.6	1626.0	1365.0

Note.

1. reference DPT Report No. : SKDPT-20141031-02.

1						TITLE	B.W REDUCING TEE			
0	FEB.23. 2019	FOR REFERENCE	K.R PARK	J.H PARK	J.H YOON	<b>SUNGKWANG BEND CO., LTD.</b>				
REV. No.	DATE	DESCRIPTION	DRAWN	REVIEWED	APPROVED	SKB DWG No. SKB-R19022307 REV.0		SKB JOB No. N/A		
" THIS DRAWING IS THE PROPERTY OF <b>SUNGKWANG BEND CO., LTD.</b> AND MUST NOT BE COPIED OR USED FOR MANUFACTURE WITHOUT PERMISSION."							SCALE NONE	UNIT mm	PAPER SIZE A4	SHEET No. 7 OF 13

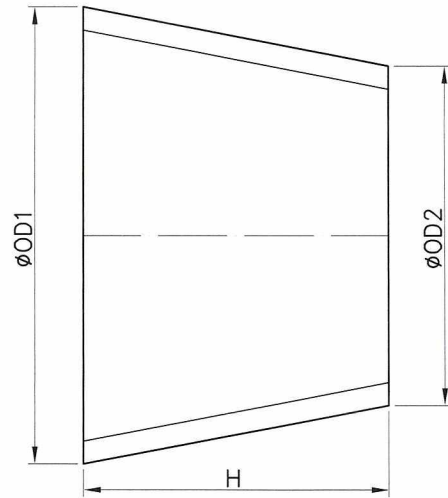

CON. REDUCER

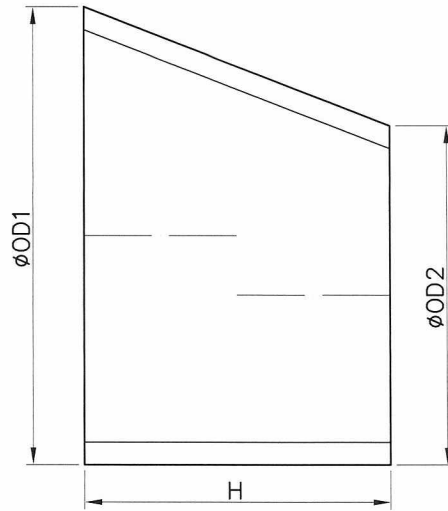

ECC. REDUCER

SIZE(inch)	OD1(mm)	OD2(mm)	H(mm)
62 X 60	1574.8	1524.0	711.2
62 X 58	1574.8	1473.2	711.2
62 X 56	1574.8	1422.4	711.2
62 X 54	1574.8	1371.6	1041.4
62 X 52	1574.8	1320.8	1041.4
62 X 50	1574.8	1270.0	1447.8
62 X 48	1574.8	1219.2	1447.8
62 X 46	1574.8	1168.4	1905.0
62 X 44	1574.8	1117.6	1905.0
62 X 42	1574.8	1066.8	2108.2

SIZE(inch)	OD1(mm)	OD2(mm)	H(mm)
64 X 62	1625.6	1574.8	711.2
64 X 60	1625.6	1524.0	711.2
64 X 58	1625.6	1473.2	711.2
64 X 56	1625.6	1422.4	1041.4
64 X 54	1625.6	1371.6	1041.4
64 X 52	1625.6	1320.8	1447.8
64 X 50	1625.6	1270.0	1447.8
64 X 48	1625.6	1219.2	1905.0
64 X 46	1625.6	1168.4	1905.0
64 X 44	1625.6	1117.6	2108.2

SIZE(inch)	OD1(mm)	OD2(mm)	H(mm)
66 X 64	1676.4	1625.6	711.2
66 X 62	1676.4	1574.8	711.2
66 X 60	1676.4	1524.0	711.2
66 X 58	1676.4	1473.2	1041.4
66 X 56	1676.4	1422.4	1041.4
66 X 54	1676.4	1371.6	1447.8
66 X 52	1676.4	1320.8	1447.8
66 X 50	1676.4	1270.0	1905.0
66 X 48	1676.4	1219.2	1905.0
66 X 46	1676.4	1168.4	2108.2

SIZE(inch)	OD1(mm)	OD2(mm)	H(mm)
68 X 66	1727.2	1676.4	711.2
68 X 64	1727.2	1625.6	711.2
68 X 62	1727.2	1574.8	711.2
68 X 60	1727.2	1524.0	1041.4
68 X 58	1727.2	1473.2	1041.4
68 X 56	1727.2	1422.4	1447.8
68 X 54	1727.2	1371.6	1447.8
68 X 52	1727.2	1320.8	1905.0
68 X 50	1727.2	1270.0	1905.0
68 X 48	1727.2	1219.2	2108.2

Note.

- reference DPT Report No. :  
SKDPT-20141107-03 ( CON. REDUCER)  
SKDPT-20141110-03 ( ECC. REDUCER)

1						TITLE	B.W REDUCER			
0	FEB.23. 2019	FOR REFERENCE	K.R PARK	J.H PARK	J.H YOON	 <b>SUNGKWANG BEND CO., LTD.</b>				
REV. No.	DATE	DESCRIPTION	DRAWN	REVIEWED	APPROVED	SKB DWG No. SKB-R19022308 REV.0		SKB JOB No. N/A		
" THIS DRAWING IS THE PROPERTY OF <b>SUNGKWANG BEND CO., LTD.</b> AND MUST NOT BE COPIED OR USED FOR MANUFACTURE WITHOUT PERMISSION."							SCALE NONE	UNIT mm	PAPER SIZE A4	SHEET No. 8 OF 13

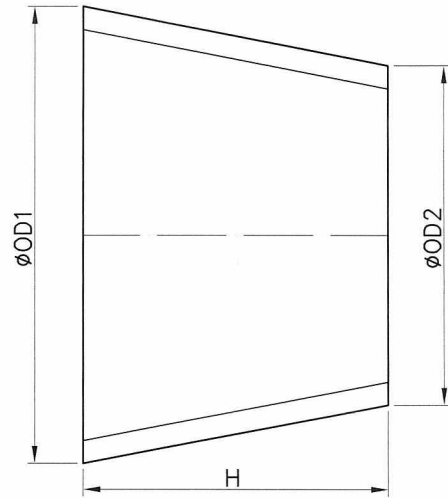

CON. REDUCER

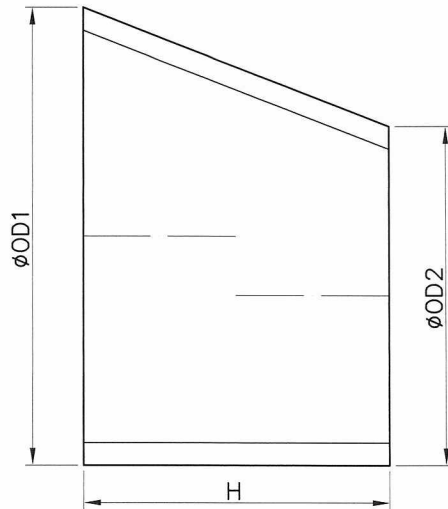

ECC. REDUCER

SIZE(inch)	OD1(mm)	OD2(mm)	H(mm)
70 X 68	1778.0	1727.2	711.2
70 X 66	1778.0	1676.4	711.2
70 X 64	1778.0	1625.6	711.2
70 X 62	1778.0	1574.8	1041.4
70 X 60	1778.0	1524.0	1041.4
70 X 58	1778.0	1473.2	1447.8
70 X 56	1778.0	1422.4	1447.8
70 X 54	1778.0	1371.6	1905.0
70 X 52	1778.0	1320.8	1905.0
70 X 50	1778.0	1270.0	2108.2



SIZE(inch)	OD1(mm)	OD2(mm)	H(mm)
72 X 70	1828.8	1778.0	711.2
72 X 68	1828.8	1727.2	711.2
72 X 66	1828.8	1676.4	711.2
72 X 64	1828.8	1625.6	1041.4
72 X 62	1828.8	1574.8	1041.4
72 X 60	1828.8	1524.0	1447.8
72 X 58	1828.8	1473.2	1447.8
72 X 56	1828.8	1422.4	1905.0
72 X 54	1828.8	1371.6	1905.0
72 X 52	1828.8	1320.8	2108.2

SIZE(inch)	OD1(mm)	OD2(mm)	H(mm)
74 X 72	1879.6	1828.8	711.2
74 X 70	1879.6	1778.0	711.2
74 X 68	1879.6	1727.2	711.2
74 X 66	1879.6	1676.4	1041.4
74 X 64	1879.6	1625.6	1041.4
74 X 62	1879.6	1574.8	1447.8
74 X 60	1879.6	1524.0	1447.8
74 X 58	1879.6	1473.2	1905.0
74 X 56	1879.6	1422.4	1905.0
74 X 54	1879.6	1371.6	2108.2

SIZE(inch)	OD1(mm)	OD2(mm)	H(mm)
76 X 74	1930.4	1879.6	711.2
76 X 72	1930.4	1828.8	711.2
76 X 70	1930.4	1778.0	711.2
76 X 68	1930.4	1727.2	1041.4
76 X 66	1930.4	1676.4	1041.4
76 X 64	1930.4	1625.6	1447.8
76 X 62	1930.4	1574.8	1447.8
76 X 60	1930.4	1524.0	1905.0
76 X 58	1930.4	1473.2	1905.0
76 X 56	1930.4	1422.4	2108.2

Note.

- reference DPT Report No. :  
SKDPT-20141107-03 ( CON. REDUCER)  
SKDPT-20141110-03 ( ECC. REDUCER)

REV. No.	DATE	DESCRIPTION	DRAWN	REVIEWED	APPROVED	TITLE	SKB DWG No.	SKB JOB No.		
1						B.W REDUCER				
0	FEB.23. 2019	FOR REFERENCE	K.R PARK	J.H PARK	J.H YOON	 <b>SUNGKWANG BEND CO., LTD.</b>				
						SKB-R19022309 REV.0	N/A			
" THIS DRAWING IS THE PROPERTY OF <b>SUNGKWANG BEND CO., LTD.</b> AND MUST NOT BE COPIED OR USED FOR MANUFACTURE WITHOUT PERMISSION."							SCALE NONE	UNIT mm	PAPER SIZE A4	SHEET No. 9 OF 13

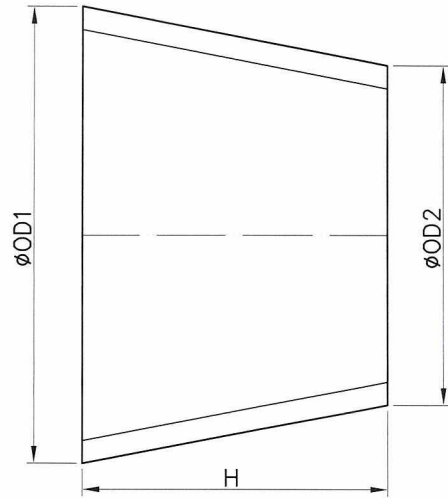

CON. REDUCER

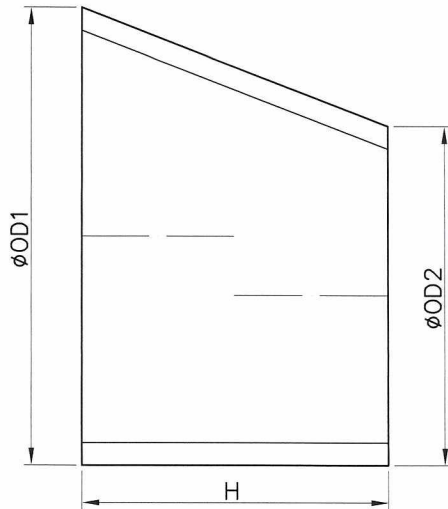

ECC. REDUCER

SIZE(inch)	OD1(mm)	OD2(mm)	H(mm)
78 X 76	1981.2	1930.4	711.2
78 X 74	1981.2	1879.6	711.2
78 X 72	1981.2	1828.8	711.2
78 X 70	1981.2	1778.0	1041.4
78 X 68	1981.2	1727.2	1041.4
78 X 66	1981.2	1676.4	1447.8
78 X 64	1981.2	1625.6	1447.8
78 X 62	1981.2	1574.8	1905.0
78 X 60	1981.2	1524.0	1905.0
78 X 58	1981.2	1473.2	2108.2

SIZE(inch)	OD1(mm)	OD2(mm)	H(mm)
80 X 78	2032.0	1981.2	711.2
80 X 76	2032.0	1930.4	711.2
80 X 74	2032.0	1879.6	711.2
80 X 72	2032.0	1828.8	1041.4
80 X 70	2032.0	1778.0	1041.4
80 X 68	2032.0	1727.2	1447.8
80 X 66	2032.0	1676.4	1447.8
80 X 64	2032.0	1625.6	1905.0
80 X 62	2032.0	1574.8	1905.0
80 X 60	2032.0	1524.0	2108.2

SIZE(inch)	OD1(mm)	OD2(mm)	H(mm)
82 X 80	2082.8	2032.0	711.2
82 X 78	2082.8	1981.2	711.2
82 X 76	2082.8	1930.4	711.2
82 X 74	2082.8	1879.6	1041.4
82 X 72	2082.8	1828.8	1041.4
82 X 70	2082.8	1778.0	1447.8
82 X 68	2082.8	1727.2	1447.8
82 X 66	2082.8	1676.4	1905.0
82 X 64	2082.8	1625.6	1905.0
82 X 62	2082.8	1574.8	2108.2

SIZE(inch)	OD1(mm)	OD2(mm)	H(mm)
84 X 82	2133.6	2082.8	711.2
84 X 80	2133.6	2032.0	711.2
84 X 78	2133.6	1981.2	711.2
84 X 76	2133.6	1930.4	1041.4
84 X 74	2133.6	1879.6	1041.4
84 X 72	2133.6	1828.8	1447.8
84 X 70	2133.6	1778.0	1447.8
84 X 68	2133.6	1727.2	1905.0
84 X 66	2133.6	1676.4	1905.0
84 X 64	2133.6	1625.6	2108.2

Note.

- reference DPT Report No. :  
SKDPT-20141107-03 ( CON. REDUCER)  
SKDPT-20141110-03 ( ECC. REDUCER)

REV. No.	DATE	DESCRIPTION	DRAWN	REVIEWED	APPROVED	TITLE
1						B.W REDUCER
0	FEB.23. 2019	FOR REFERENCE	K.R PARK	J.H PARK	J.H YOON	SUNGKWANG BEND CO., LTD.
						SKB DWG No. SKB-R19022310 REV.0
						SKB JOB No. N/A
" THIS DRAWING IS THE PROPERTY OF <b>SUNGKWANG BEND CO., LTD.</b> AND MUST NOT BE COPIED OR USED FOR MANUFACTURE WITHOUT PERMISSION."						
			SCALE	UNIT	PAPER SIZE	SHEET No.
			NONE	mm	A4	10 OF 13

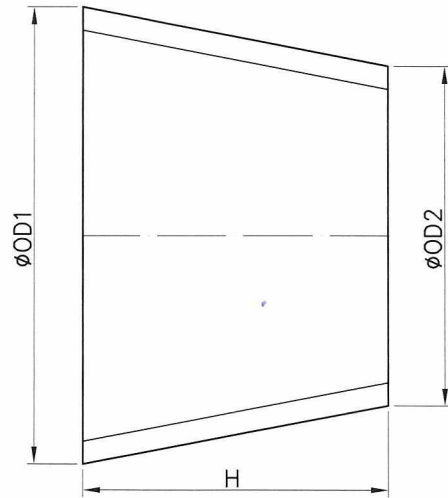

CON. REDUCER

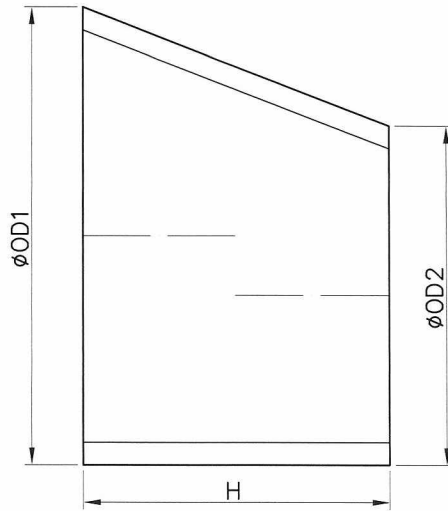

ECC. REDUCER

SIZE(inch)	OD1(mm)	OD2(mm)	H(mm)
86 X 84	2184.4	2133.6	711.2
86 X 82	2184.4	2082.8	711.2
86 X 80	2184.4	2032.0	711.2
86 X 78	2184.4	1981.2	1041.4
86 X 76	2184.4	1930.4	1041.4
86 X 74	2184.4	1879.6	1447.8
86 X 72	2184.4	1828.8	1447.8
86 X 70	2184.4	1778.0	1905.0
86 X 68	2184.4	1727.2	1905.0
86 X 66	2184.4	1676.4	2108.2

SIZE(inch)	OD1(mm)	OD2(mm)	H(mm)
88 X 86	2235.2	2184.4	711.2
88 X 84	2235.2	2133.6	711.2
88 X 82	2235.2	2082.8	711.2
88 X 80	2235.2	2032.0	1041.4
88 X 78	2235.2	1981.2	1041.4
88 X 76	2235.2	1930.4	1447.8
88 X 74	2235.2	1879.6	1447.8
88 X 72	2235.2	1828.8	1905.0
88 X 70	2235.2	1778.0	1905.0
88 X 68	2235.2	1727.2	2108.2

SIZE(inch)	OD1(mm)	OD2(mm)	H(mm)
90 X 88	2286.0	2235.2	711.2
90 X 86	2286.0	2184.4	711.2
90 X 84	2286.0	2133.6	711.2
90 X 82	2286.0	2082.8	1041.4
90 X 80	2286.0	2032.0	1041.4
90 X 78	2286.0	1981.2	1447.8
90 X 76	2286.0	1930.4	1447.8
90 X 74	2286.0	1879.6	1905.0
90 X 72	2286.0	1828.8	1905.0
90 X 70	2286.0	1778.0	2108.2

SIZE(inch)	OD1(mm)	OD2(mm)	H(mm)
92 X 90	2336.8	2286.0	711.2
92 X 88	2336.8	2235.2	711.2
92 X 86	2336.8	2184.4	711.2
92 X 84	2336.8	2133.6	1041.4
92 X 82	2336.8	2082.8	1041.4
92 X 80	2336.8	2032.0	1447.8
92 X 78	2336.8	1981.2	1447.8
92 X 76	2336.8	1930.4	1905.0
92 X 74	2336.8	1879.6	1905.0
92 X 72	2336.8	1828.8	2108.2

Note.

- reference DPT Report No. :  
SKDPT-20141107-03 ( CON. REDUCER)  
SKDPT-20141110-03 ( ECC. REDUCER)

1						TITLE	B.W REDUCER			
0	FEB.23. 2019	FOR REFERENCE	K.R PARK	J.H PARK	J.H YOON	<b>SUNGKWANG BEND CO., LTD.</b>				
REV. No.	DATE	DESCRIPTION	DRAWN	REVIEWED	APPROVED	SKB DWG No.	SKB JOB No.			
						SKB-R19022311 REV.0	N/A			
" THIS DRAWING IS THE PROPERTY OF <b>SUNGKWANG BEND CO., LTD.</b> AND MUST NOT BE COPIED OR USED FOR MANUFACTURE WITHOUT PERMISSION."						 SCALE NONE	 UNIT mm	 PAPER SIZE A4	 SHEET No. 11 OF 13	

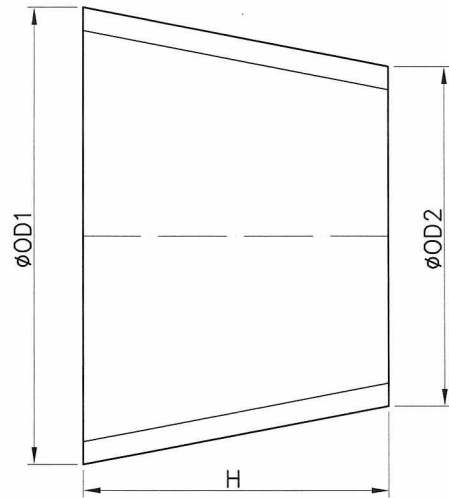

CON. REDUCER

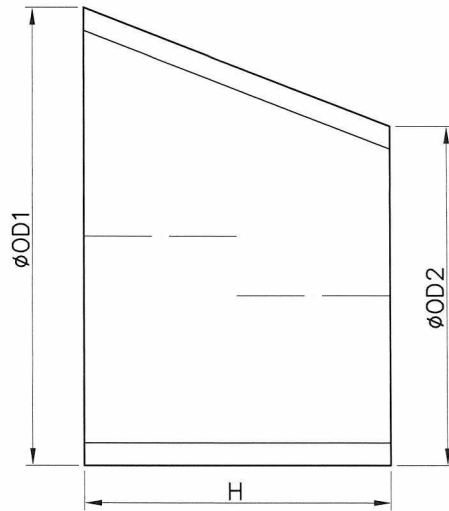



ECC. REDUCER

SIZE(inch)	OD1(mm)	OD2(mm)	H(mm)
94 X 92	2387.6	2336.8	711.2
94 X 90	2387.6	2286.0	711.2
94 X 88	2387.6	2235.2	711.2
94 X 86	2387.6	2184.4	1041.4
94 X 84	2387.6	2133.6	1041.4
94 X 82	2387.6	2082.8	1447.8
94 X 80	2387.6	2032.0	1447.8
94 X 78	2387.6	1981.2	1905.0
94 X 76	2387.6	1930.4	1905.0
94 X 74	2387.6	1879.6	2108.2

SIZE(inch)	OD1(mm)	OD2(mm)	H(mm)
96 X 94	2438.4	2387.6	711.2
96 X 92	2438.4	2336.8	711.2
96 X 90	2438.4	2286.0	711.2
96 X 88	2438.4	2235.2	1041.4
96 X 86	2438.4	2184.4	1041.4
96 X 84	2438.4	2133.6	1447.8
96 X 82	2438.4	2082.8	1447.8
96 X 80	2438.4	2032.0	1905.0
96 X 78	2438.4	1981.2	1905.0
96 X 76	2438.4	1930.4	2108.2

Note.

- reference DPT Report No. :  
 SKDPT-20141107-03 ( CON. REDUCER)  
 SKDPT-20141110-03 ( ECC. REDUCER)

1						TITLE	B.W REDUCER			
0	FEB.23. 2019	FOR REFERENCE	K.R PARK	J.H PARK	J.H YOON	 <b>SUNGKWANG BEND CO., LTD.</b>				
REV. No.	DATE	DESCRIPTION	DRAWN	REVIEWED	APPROVED	SKB DWG No. SKB-R19022312 REV.0		SKB JOB No. N/A		
" THIS DRAWING IS THE PROPERTY OF <b>SUNGKWANG BEND CO., LTD.</b> AND MUST NOT BE COPIED OR USED FOR MANUFACTURE WITHOUT PERMISSION."							SCALE NONE	UNIT mm	PAPER SIZE A4	SHEET No. 12 OF 13



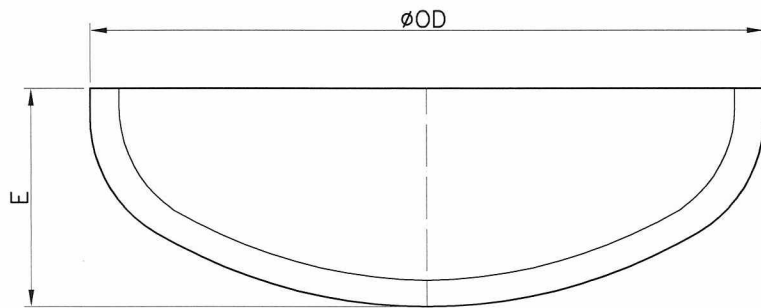



CAP

SIZE(inch)	OD(mm)	E(mm)
62	1574.8	445.0
64	1625.6	445.0
66	1676.4	457.0
68	1727.2	469.0
70	1778.0	495.0
72	1828.8	495.0
74	1879.6	521.0
76	1930.4	521.0
78	1981.2	533.0
80	2032.0	546.0
82	2082.8	571.0
84	2133.6	571.0
86	2184.4	610.0
88	2235.2	610.0
90	2286.0	610.0
92	2336.8	635.0
94	2387.6	635.0
96	2438.4	650.0

Note.

1. reference DPT Report No. : SKDPT-20141107-06.

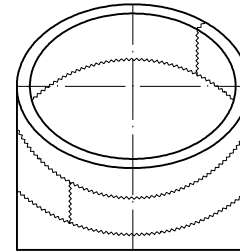
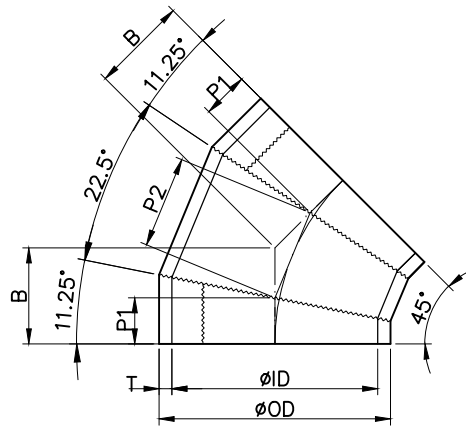

REV. No.	DATE	DESCRIPTION	DRAWN	REVIEWED	APPROVED	TITLE	SKB DWG No.	SKB JOB No.		
1						B.W CAP				
0	FEB.23. 2019	FOR REFERENCE	K.R PARK	J.H PARK	J.H YOON	 <b>SUNGKWANG BEND CO., LTD.</b>				
						SKB-R19022313 REV.0	N/A			
" THIS DRAWING IS THE PROPERTY OF <b>SUNGKWANG BEND CO., LTD.</b> AND MUST NOT BE COPIED OR USED FOR MANUFACTURE WITHOUT PERMISSION."							SCALE NONE	UNIT mm	PAPER SIZE A4	SHEET No. 13 OF 13

SIZE	MATERIAL	OD	ID	T	P1	P2	B
96" 17.48T	A403WP304/L-W	2438.4	2403.4	17.48	727.5	1455.1	1515.0
102" 19.05T	A403WP304/L-W	2590.8	2552.7	19.05	773.0	1546.0	1609.7
110" 20.62T	A403WP304/L-W	2794.0	2752.8	20.62	833.6	1667.3	1736.0



Note.

1. reference 'calculation No. : SKB-C190220-06 REV.0.

REV. No.	DATE	DESCRIPTION	DRAWN	REVIEWED	APPROVED	TITLE
1						B.W 45D L-R MITER
0	FEB.25, 2019	FOR REFERENCE	K.R PARK	J.H PARK	J.H YOON	 <b>SUNGKWANG BEND CO., LTD.</b>
						SKB DWG No. <b>SKB-S19022501 REV.0</b> SKB JOB No. <b>N/A</b>
" THIS DRAWING IS THE PROPERTY OF SUNGKWANG BEND CO., LTD. AND MUST NOT BE COPIED OR USED FOR MANUFACTURE WITHOUT PERMISSION."						  SCALE NONE UNIT mm PAPER SIZE A4 SHEET No. 1 OF 6

SIZE	MATERIAL	OD	ID	T	P1	P2	A
96" 17.48T	A403WP304/L-W	2438.4	2403.4	17.48	727.5	1455.1	3657.6
102" 19.05T	A403WP304/L-W	2590.8	2552.7	19.05	773.0	1546.0	3886.2
110" 20.62T	A403WP304/L-W	2794.0	2752.8	20.62	833.6	1667.3	4191.0

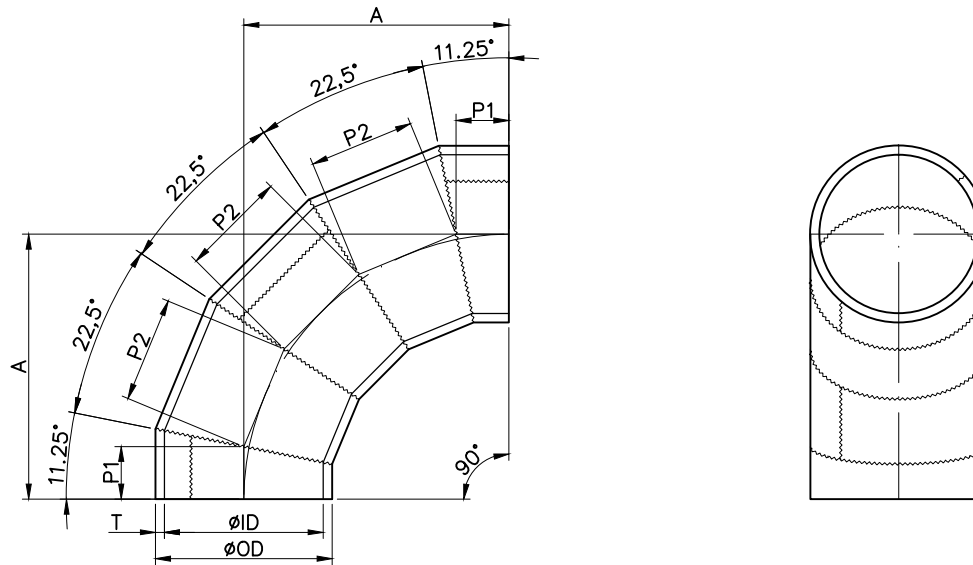

Note.  
1. reference 'calculation No. : SKB-C190220-05 REV.0.

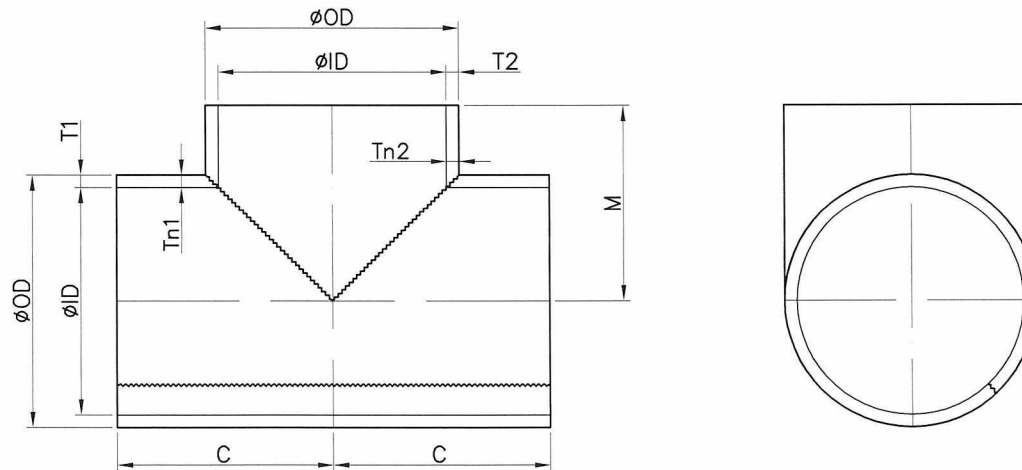

REV. No.	DATE	DESCRIPTION	DRAWN	REVIEWED	APPROVED	TITLE	SKB DWG No.	SKB JOB No.		
1						B.W 90D L-R MITER				
0	FEB.25, 2019	FOR REFERENCE	K.R PARK	J.H PARK	J.H YOON	SUNGKWANG BEND CO., LTD.				
						SKB-S19022502 REV.0	N/A			
" THIS DRAWING IS THE PROPERTY OF SUNGKWANG BEND CO., LTD. AND MUST NOT BE COPIED OR USED FOR MANUFACTURE WITHOUT PERMISSION."							SCALE NONE	UNIT mm	PAPER SIZE A4	SHEET No. 2 OF 6

SIZE	MATERIAL	OD1	ID1	Tn1	T1	OD2	ID2	Tn2	T2	C	M	
88"	15.88T	A403WP304/L-W	2235.2	2203.4	22.70	15.88	2235.2	2203.4	15.88	15.88	1651.0	1549.4
88"	20.62T	A403WP304/L-W	2235.2	2194.0	22.70	20.62	2235.2	2194.0	20.62	20.62	1651.0	1549.4
88"	23.83T	A403WP304/L-W	2235.2	2187.5	23.83	23.83	2235.2	2187.5	23.83	23.83	1651.0	1549.4
88"	31.80T	A403WP304/L-W	2235.2	2171.6	31.80	31.80	2235.2	2171.6	31.80	31.80	1651.0	1549.4
96"	17.48T	A403WP304/L-W	2438.4	2403.4	24.70	17.48	2438.4	2403.4	17.48	17.48	1803.4	1701.8
102"	19.05T	A403WP304/L-W	2590.8	2552.7	26.30	19.05	2590.8	2552.7	19.05	19.05	1905.0	1803.4
110"	20.62T	A403WP304/L-W	2794.0	2752.8	28.30	20.62	2794.0	2752.8	20.62	20.62	2057.4	1955.8



Note.

1. reference calculation No. : SKB-C190220-07 REV.0.

REV. No.	DATE	DESCRIPTION	DRAWN	REVIEWED	APPROVED	TITLE
1						B.W STRAIGHT TEE
0	FEB.25, 2019	FOR REFERENCE	K.R PARK	J.H PARK	J.H YOON	 <b>SUNGKWANG BEND CO., LTD.</b>
						SKB DWG No. SKB-S19022503 REV.0
						SKB JOB No. N/A
" THIS DRAWING IS THE PROPERTY OF <b>SUNGKWANG BEND CO., LTD.</b> AND MUST NOT BE COPIED OR USED FOR MANUFACTURE WITHOUT PERMISSION."						  SCALE NONE UNIT mm PAPER SIZE A4 SHEET No. 3 OF 6

SIZE	MATERIAL	OD1	ID1	Tn1	T1	OD2	ID2	Tn2	T2	C	M
88" X 72" 15.88T X 14.27T	A403WP304/L-W	2235.2	2203.4	22.70	15.88	1828.8	1800.3	14.27	14.27	1651.0	1549.4

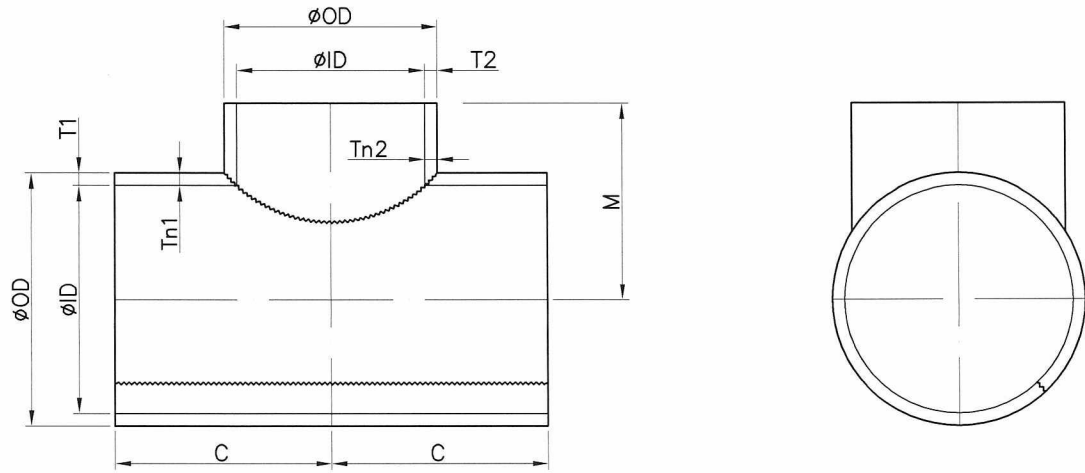

Note.

1. reference 'calculation No. : SKB-C190220-07 REV.0.

REV. No.	DATE	DESCRIPTION	DRAWN	REVIEWED	APPROVED	TITLE
1						B.W REDUCING TEE
0	FEB.25, 2019	FOR REFERENCE	K.R PARK	J.H PARK	J.H YOON	SUNGKWANG BEND CO., LTD.
						SKB DWG No. SKB-S19022504 REV.0
						SKB JOB No. N/A
" THIS DRAWING IS THE PROPERTY OF <b>SUNGKWANG BEND CO., LTD.</b> AND MUST NOT BE COPIED OR USED FOR MANUFACTURE WITHOUT PERMISSION."						SCALE NONE UNIT mm PAPER SIZE A4 SHEET No. 4 OF 6

SIZE	MATERIAL	OD1	ID1	T1	OD2	ID2	T2	H	A°
102" x 80" 19.05T x 14.27T	A403WP304/L-W	2590.8	2552.7	19.05	2032.0	2003.5	14.27	2286.0	13.51
102" x 88" 19.05T x 19.05T	A403WP304/L-W	2590.8	2552.7	19.05	2235.2	2197.1	19.05	1447.8	13.56
102" x 96" 19.05T x 17.48T	A403WP304/L-W	2590.8	2552.7	19.05	2438.4	2403.4	17.48	1041.4	8.16
110" x 88" 20.62T x 15.88T	A403WP304/L-W	2794.0	2752.8	20.62	2235.2	2203.4	15.88	2286.0	13.51
110" x 96" 20.62T x 17.48T	A403WP304/L-W	2794.0	2752.8	20.62	2438.4	2403.4	17.48	1447.8	13.57
110" x 102" 20.62T x 19.05T	A403WP304/L-W	2794.0	2752.8	20.62	2590.8	2552.7	19.05	1041.4	10.87

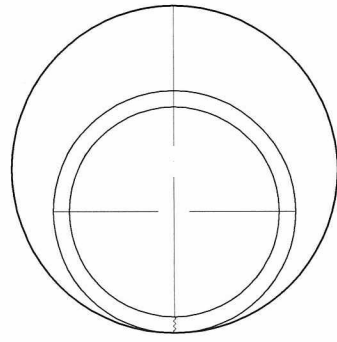
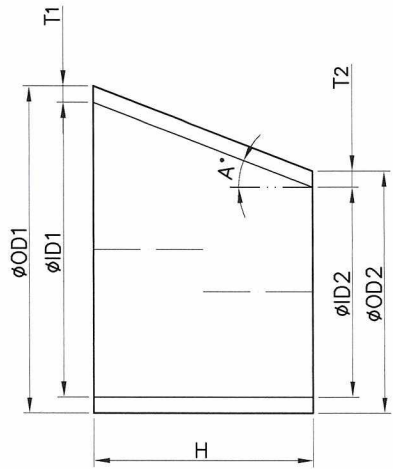

Note.  
1. reference 'calculation No. : SKB-C190220-03 REV.0.

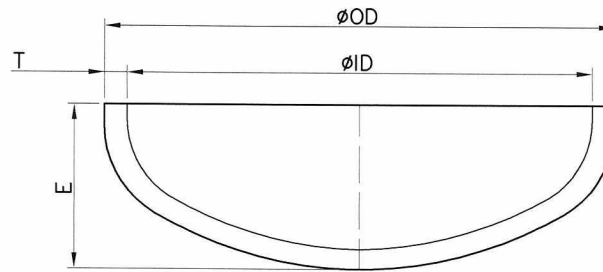

1						TITLE	<b>B.W ECC. REDUCER (conical type)</b>			
0	FEB.25, 2019	FOR REFERENCE	K.R PARK	J.H PARK	J.H YOON	<b>SUNGKWANG BEND CO., LTD.</b>				
REV. No.	DATE	DESCRIPTION	DRAWN	REVIEWED	APPROVED	SKB DWG No. <b>SKB-S19022505 REV.0</b>	SKB JOB No. <b>N/A</b>			
" THIS DRAWING IS THE PROPERTY OF <b>SUNGKWANG BEND CO., LTD.</b> AND MUST NOT BE COPIED OR USED FOR MANUFACTURE WITHOUT PERMISSION."							SCALE NONE	UNIT mm	PAPER SIZE A4	SHEET No. 5 OF 6

SIZE	MATERIAL	OD	ID	T	E
102" 19.05T	A403WP304/L-S	2590.8	2552.7	19.05	687.0
110" 20.62T	A403WP304/L-S	2794.0	2752.8	20.62	748.0



Note.

1. reference calculation No. : SKB-C190220-04 REV.0.

REV. No.	DATE	DESCRIPTION	DRAWN	REVIEWED	APPROVED	TITLE
1						B.W CAP
0	FEB.25, 2019	FOR REFERENCE	K.R PARK	J.H PARK	J.H YOON	 <b>SUNGKWANG BEND CO., LTD.</b>
						SKB DWG No. SKB-S19022506 REV.0
						SKB JOB No. N/A
" THIS DRAWING IS THE PROPERTY OF <b>SUNGKWANG BEND CO., LTD.</b> AND MUST NOT BE COPIED OR USED FOR MANUFACTURE WITHOUT PERMISSION."						 
		SCALE	UNIT	PAPER SIZE	SHEET No.	
		NONE	mm	A4	6 OF 6	